

# OFFICE CHAIR ASSEMBLY INSTRUCTION

## CHAISE DE BUREAU INSTRUCTIONS D'ASSEMBLAGE

### ASSEMBLY PROGRAM / PROGRAMME D'ASSEMBLAGE

### PARTS\*QTY / PIÈCES\*QTÉ

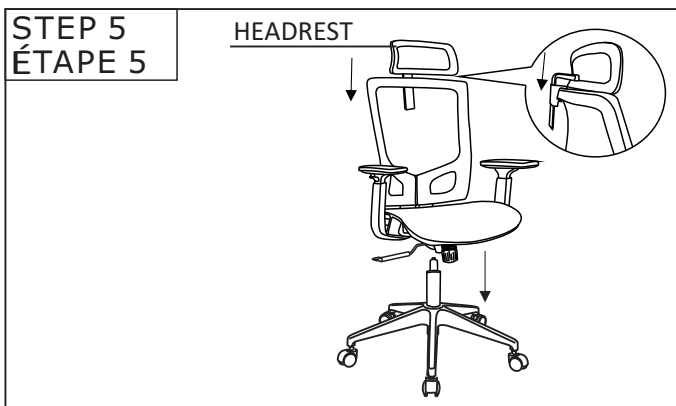
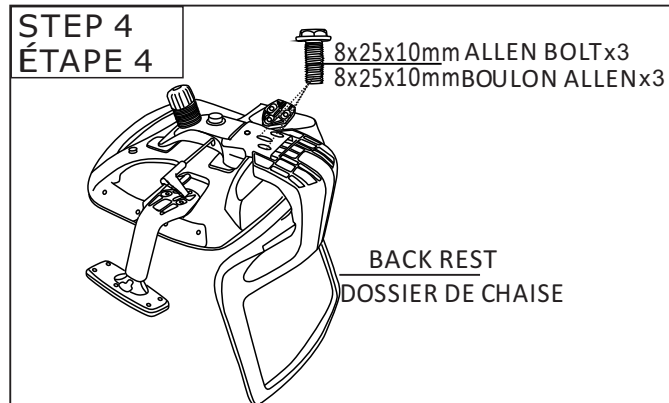
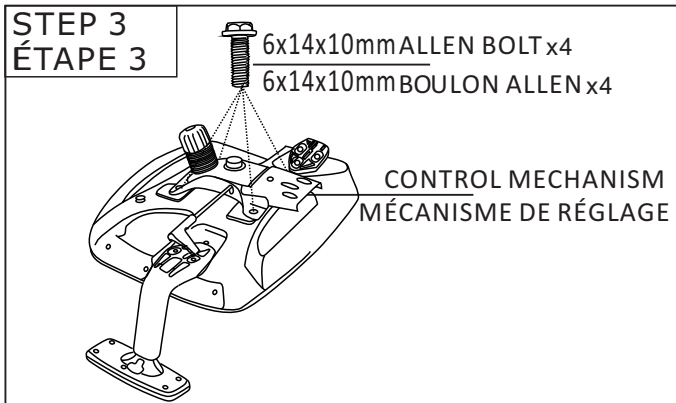
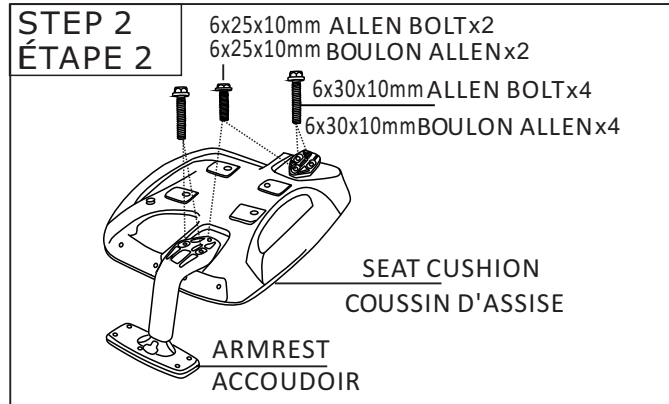
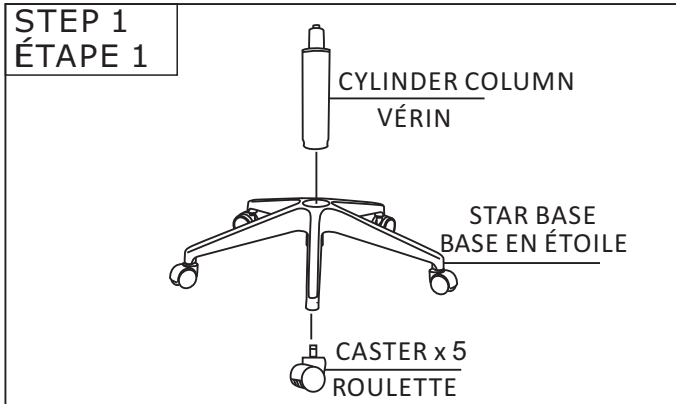

BACK REST x1 DOSSIER DE CHAISE x1	CASTER x5 ROULETTE x5
SEAT CUSHION x1 COUSSIN D'ASSISE x1	6x14x10mm ALLEN BOLT x4 6x14x10mm BOULON ALLEN x4
ARMREST x2 ACCOUDOIR x2	6x25x10mm ALLEN BOLT x2 6x25x10mm BOULON ALLEN x2
CONTROL MECHANISM x1 MÉCANISME DE RÉGLAGE x1	6x30x10mm ALLEN BOLT x4 6x30x10mm BOULON ALLEN x4
CYLINDER COLUMN x1 VÉRIN x1	8x25x10mm ALLEN BOLT x3 8x25x10mm BOULON ALLEN x3
STAR BASE x1 BASE EN ÉTOILE x1	HEADREST x1
	ALLEN WRENCH x1 CLÉ ALLEN x1