



ASSEMBLY INSTRUCTIONS

72828

HARDWARE LIST

NO.	SKETCH	DESCRIPTION	QTY
A		Bolt(5/32"x5/32") Boulon	4 PCS 4 PCES
B		Bolt(1/4"x2-1/8") Boulon	8 PCS 8 PCES
C		Bolt(1/4"x5/8") Boulon	8 PCS 8 PCES
D		Spring washer(1/4") Rondelle frein	12 PCS 12 PCES
E		Washer(1/4") Rondelle plate	12 PCS 12 PCES
F		Allen wrench(4mm) Clé hexagonale	1 PC 1 PCE
G		Allen wrench(2mm) Clé hexagonale	1 PC 1 PCE

PARTS LIST

NO.	SKETCH	DESCRIPTION	QTY
1		Seat Siège	1 PC 1 PCE
2		Backrest Dossier	1 PC 1 PCE
3		Left metal leg frame Piètement métallique gauche	1 PC 1 PCE
4		Right metal leg frame Piètement métallique droit	1 PC 1 PCE
5		Back upper rail Traverse supérieure du dossier	1 PC 1 PCE
6		Front upper rail Traverse supérieure avant	1 PC 1 PCE
7		Back Bottom Rail Rail inférieur arrière	1 PC 1 PCE
8		Footrest Repose-pieds	1 PC 1 PCE

Step 1

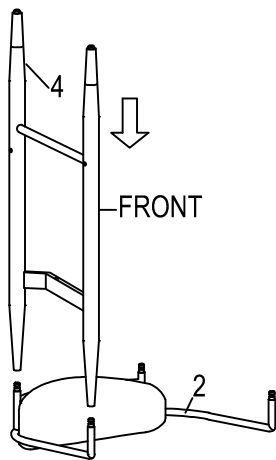

Step 2

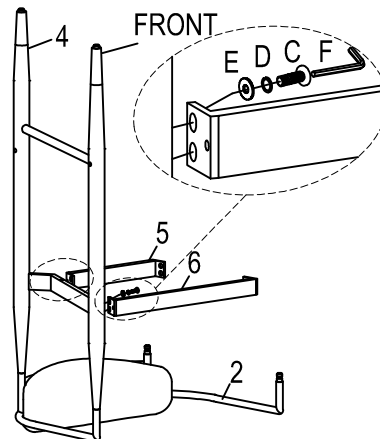

Note: Do not fully tighten the bolts at this step.

Note : Ne pas serrer complètement les boulons à cette étape.



Step 3

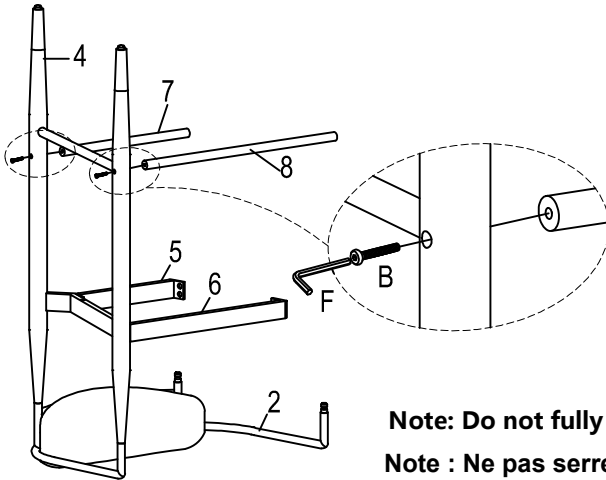

Note: Do not fully tighten the bolts at this step.

Note : Ne pas serrer complètement les boulons à cette étape.

Step 4

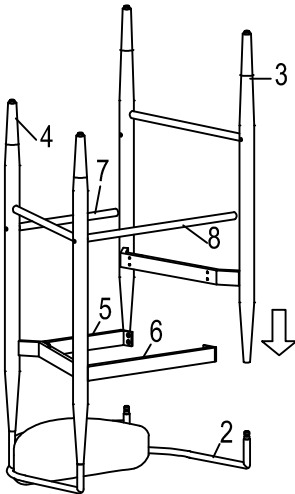

Step 5

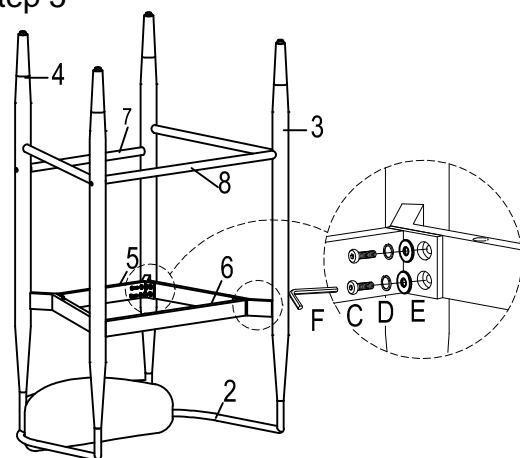

Note: Do not fully tighten the bolts at this step.

Note : Ne pas serrer complètement les boulons à cette étape.

Step 6

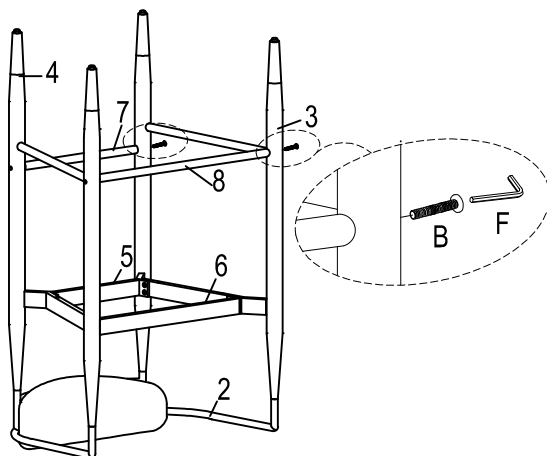

Note: Do not fully tighten the bolts at this step.

Note : Ne pas serrer complètement les boulons à cette étape.

Step 7

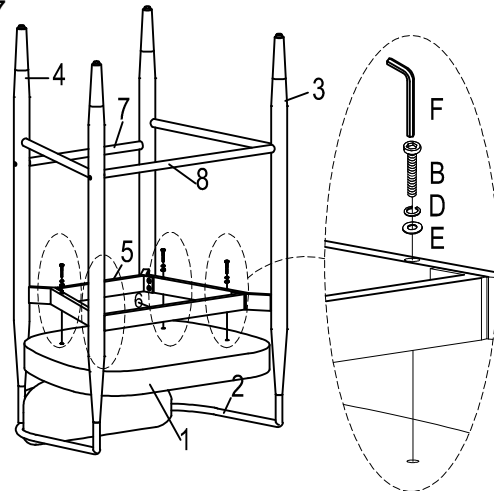

Note: Do not fully tighten the bolts at this step.

Note : Ne pas serrer complètement les boulons à cette étape.



Step 8

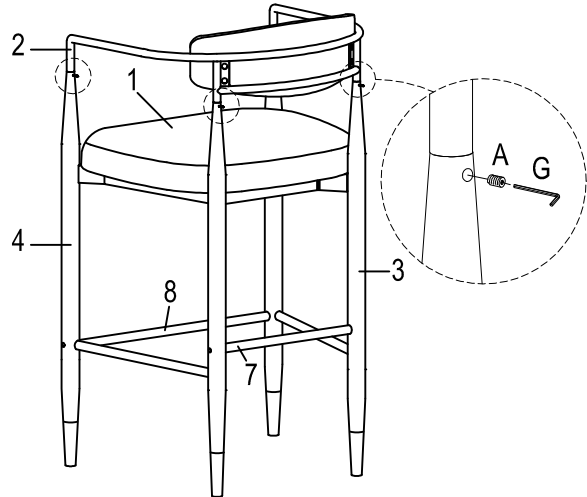
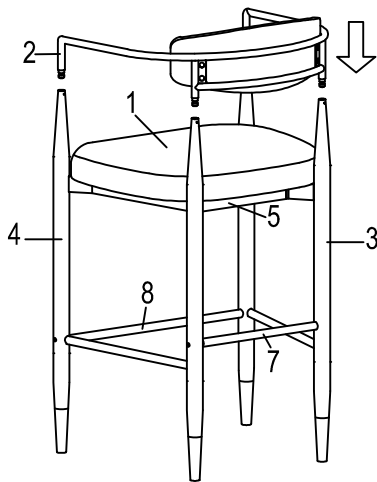

Note: Once the assembly is completed, proceed to tighten all bolts sequentially.
Remarque : une fois l'assemblage terminé, serrez tous les boulons dans l'ordre.

Step 9

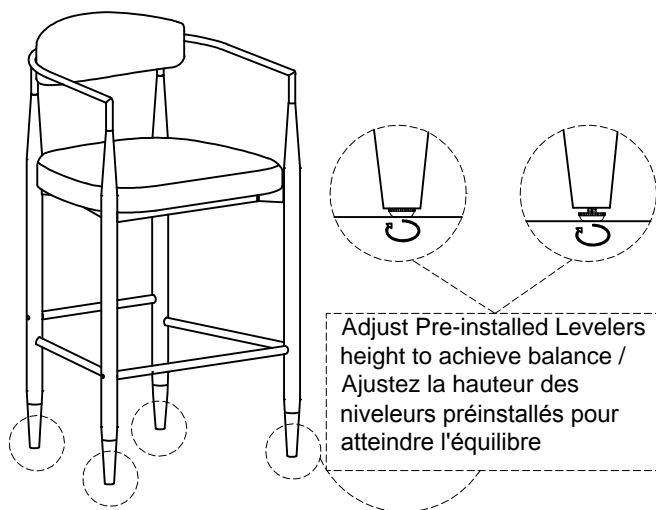

Step 10

