







ASSEMBLY INSTRUCTIONS / NOTICE D'ASSEMBLAGE

ITEM: 122327 DINING CHAIR

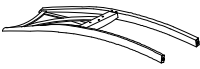



Important note/ Note importante:

1. Place all wooden parts on a clean and smooth surface such as a rug or carpet to avoid scratching the parts. / Placer les pièces sur une surface propre et lisse tel qu'une couverture ou un tapis pour éviter d'endommager les pièces.
2. Kindly follow the assembly instructions step by step./ Veuillez suivre la notice d'assemblage, pas à pas.
3. Do not tighten all screws and bolts until the table is fully assembled./ Ne serrer les vis et boulons à fond que lorsque le produit est entièrement assemblé.
4. Unscrew the protective plastique supports from the metal insert of the legs before assembly./ Dévisser les caches plastiques des embouts métalliques des pieds de la table avant l'assemblage.

PARTS IDENTIFICATION / IDENTIFICATION DES PIÈCES

A Chair Back Dossier	B Seat Frame Coussin assise	C Front Leg(L) Pied Avant Gauche	D Front Leg(R) Pied Avant Droite	E Left Stretcher(L) Traverse côté Gauche	F Right Stretcher(R) Traverse côté Droite
					
1pc	1pc	1pc	1pc	1pc	1pc

HARDWARE IDENTIFICATION / IDENTIFICATION DES PIÈCES MONTAGE

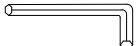
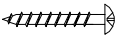
1 Bolt Boulon Ø1/4"x60mm	2 Bolt Boulon Ø1/4"x38mm	3 Long Bolt Boulon long Ø1/4"x80mm	4 Spring Washer Rondelle D'arrêt Ø1/4"x11mm	5 Flat Washer Rondelle Plate Ø1/4"x19mm	6 Allen Key Clé Allen M4	7 Wood Screw Vis #8x45mm
						
4pcs	2pcs	4pcs	10 pcs	10 pcs	1pc	4pcs

STEP 1 / ÉTAPE 1

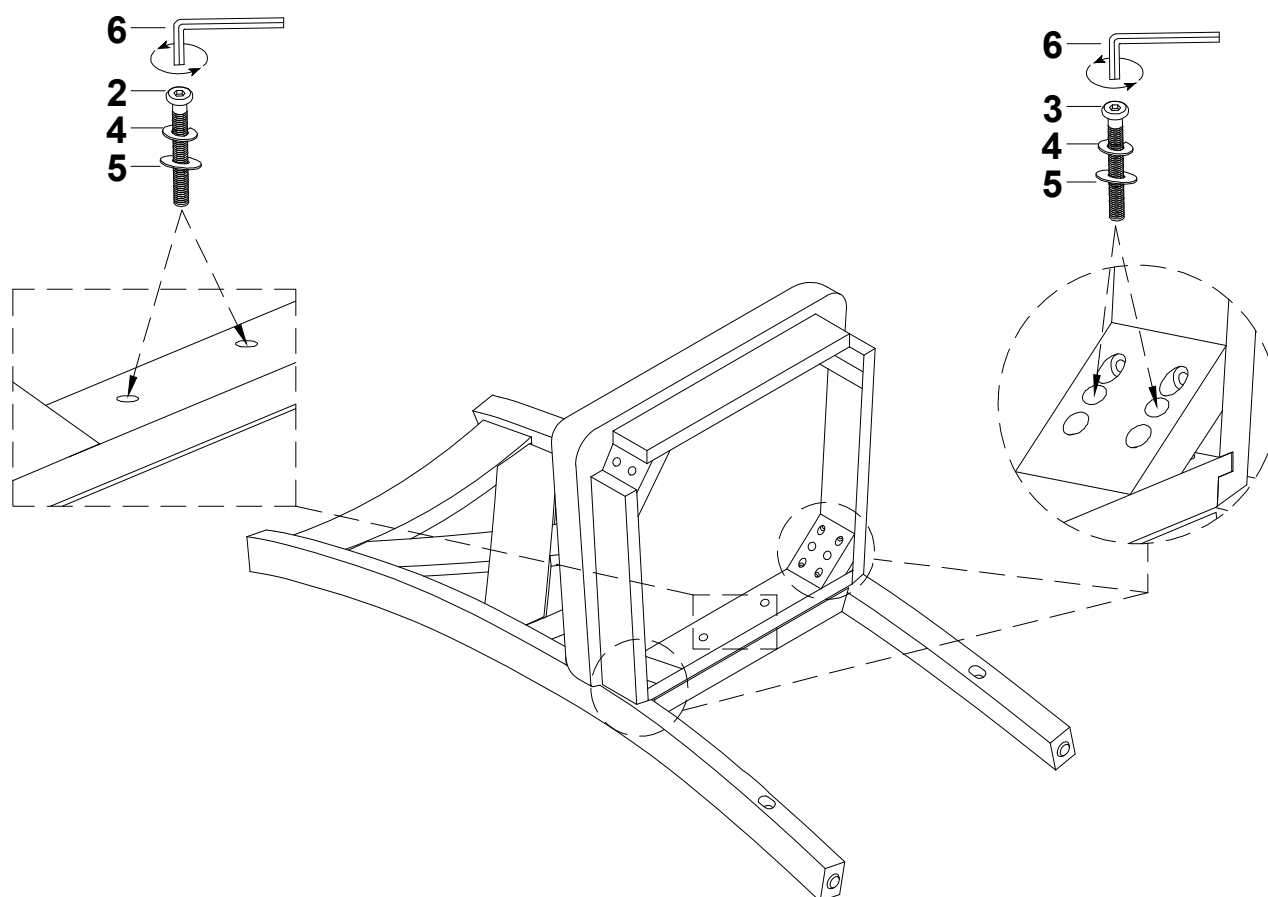

ASSEMBLY INSTRUCTIONS / NOTICE D'ASSEMBLAGE

ITEM: 122327 DINING CHAIR

STEP 2 / ÉTAPE 2

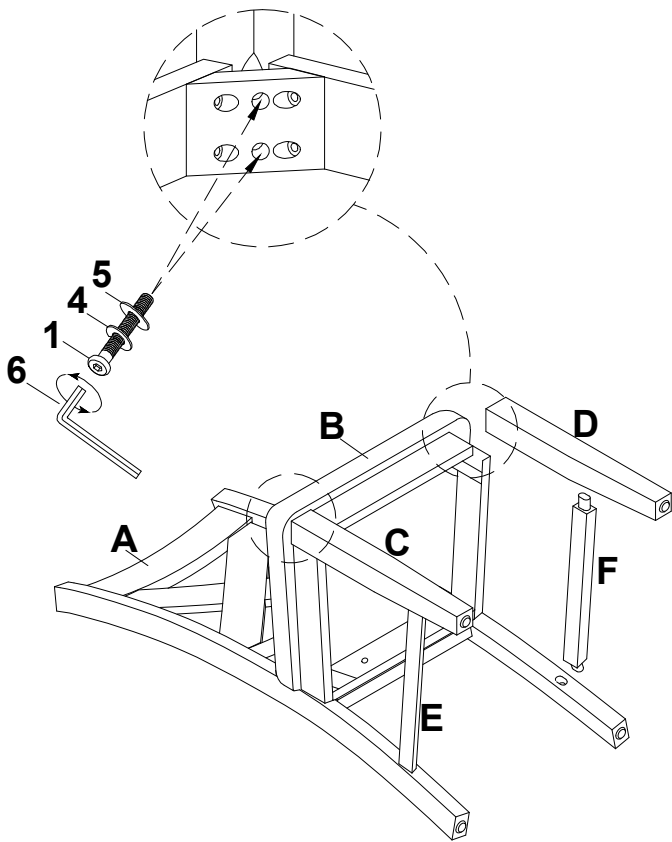

STEP 3 / ÉTAPE 3

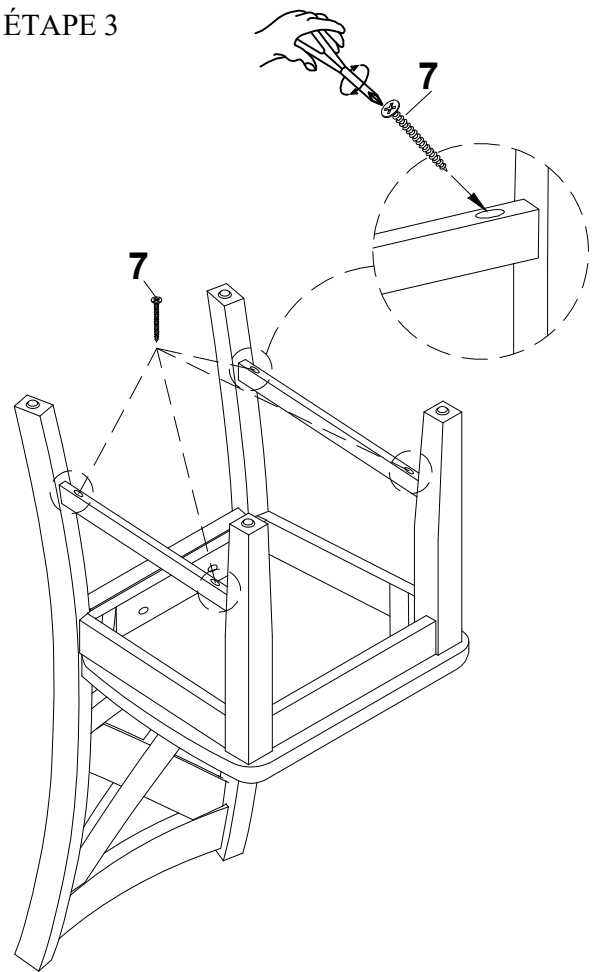

COMPLETE

