

# ASSEMBLY INSTRUCTIONS / NOTICE D'ASSEMBLAGE

## ITEM : JYP-2326T DINING TABLE

Important note/ Note importante:

1. Place all wooden parts on a clean and smooth surface such as a rug or carpet to avoid scratching the parts. / Placer les pièces sur une surface propre et lisse tel qu'une couverture ou un tapis pour éviter d'endommager les pièces.
2. Kindly follow the assembly instructions step by step./ Veuillez suivre la notice d'assemblage, pas à pas.
3. Do not tighten all screws and bolts until the table is fully assembled./ Ne serrer les vis et boulons à fond que lorsque le produit est entièrement assemblé.
4. Unscrew the protective plastic supports from the metal insert of the table legs before assembly./ Dévisser les caches plastiques des embouts métalliques des pieds de la table avant l'assemblage.

### PARTS IDENTIFICATION / IDENTIFICATION DES PIÈCES

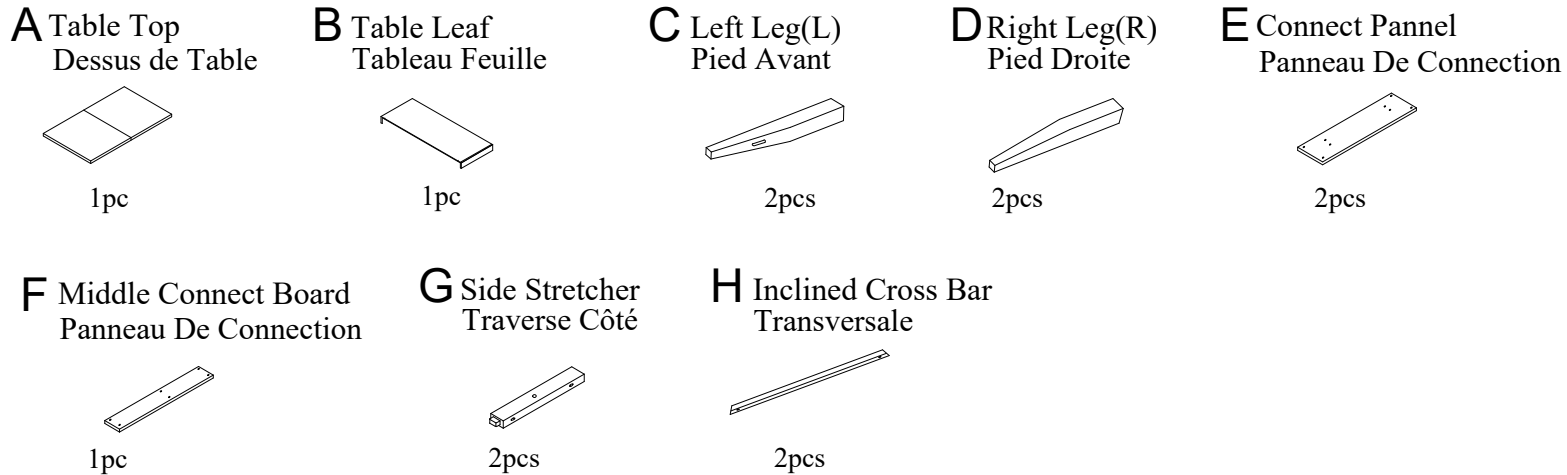

### HARDWARE IDENTIFICATION / IDENTIFICATION DES PIÈCES MONTAGE

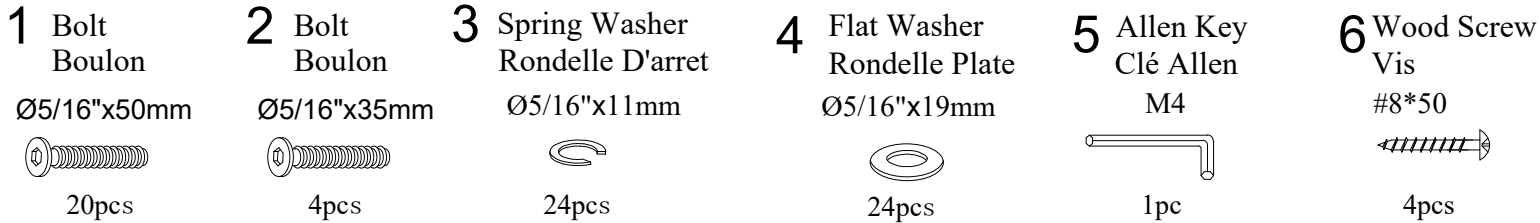

### STEP 1 / ÉTAPE 1

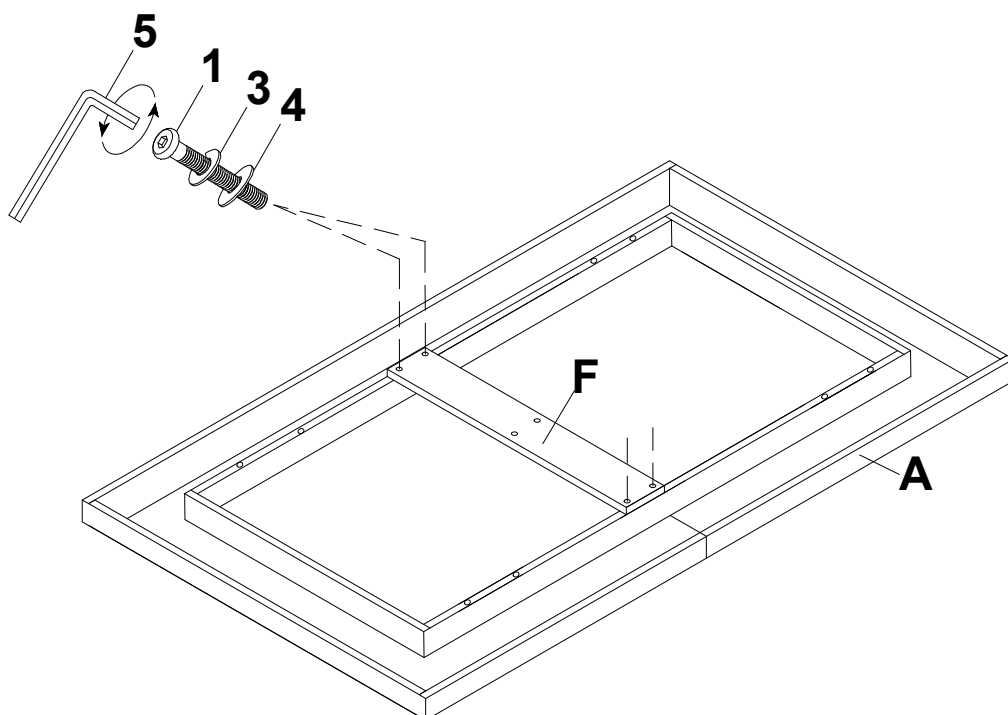

# ASSEMBLY INSTRUCTIONS / NOTICE D'ASSEMBLAGE

## ITEM : JYP-2326T DINING TABLE

### STEP 2 / ÉTAPE 2

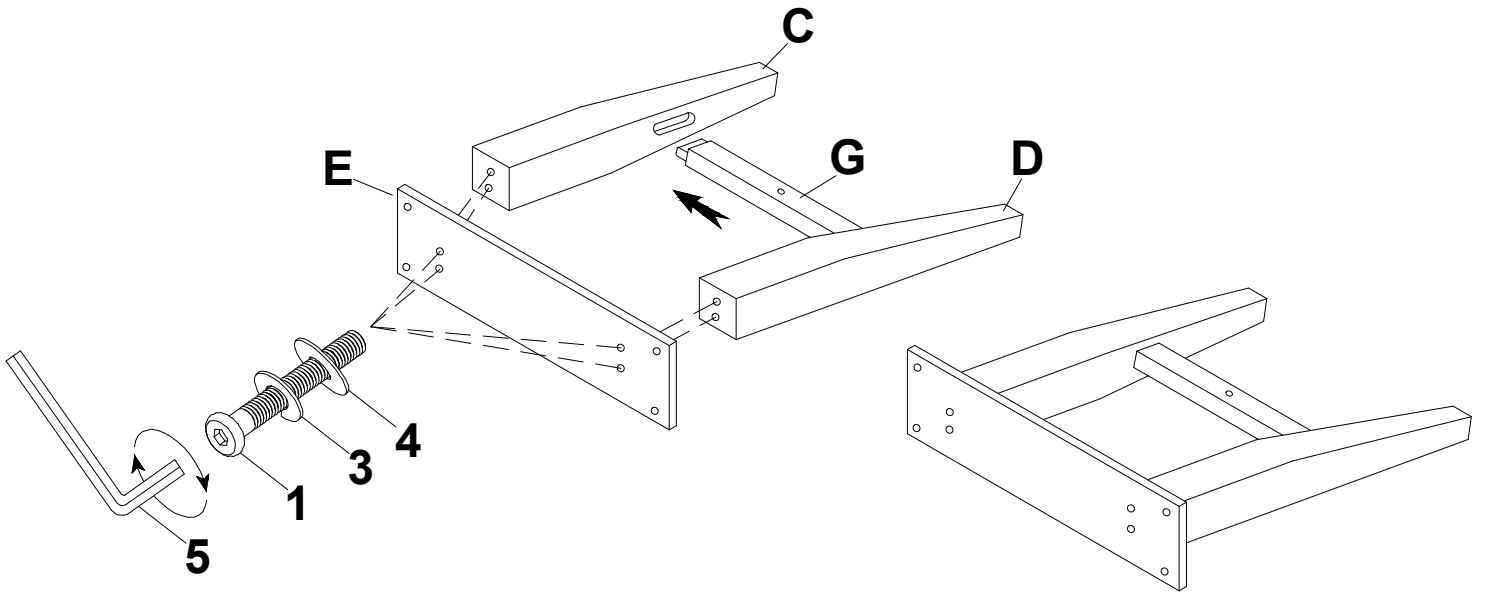

### STEP 3 / ÉTAPE 3

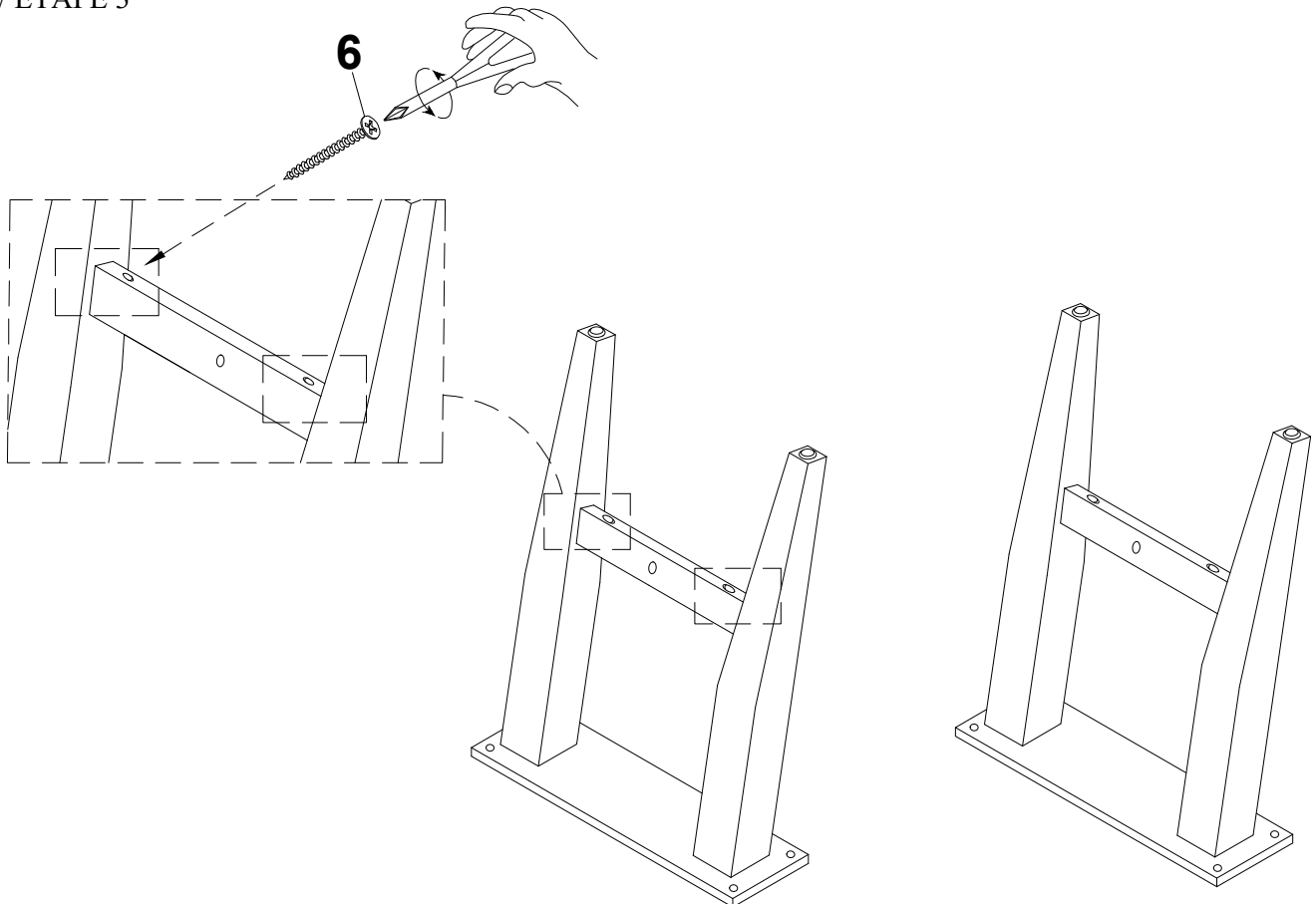

# ASSEMBLY INSTRUCTIONS / NOTICE D'ASSEMBLAGE

## ITEM : JYP-2326T DINING TABLE

### STEP 4 / ÉTAPE 4

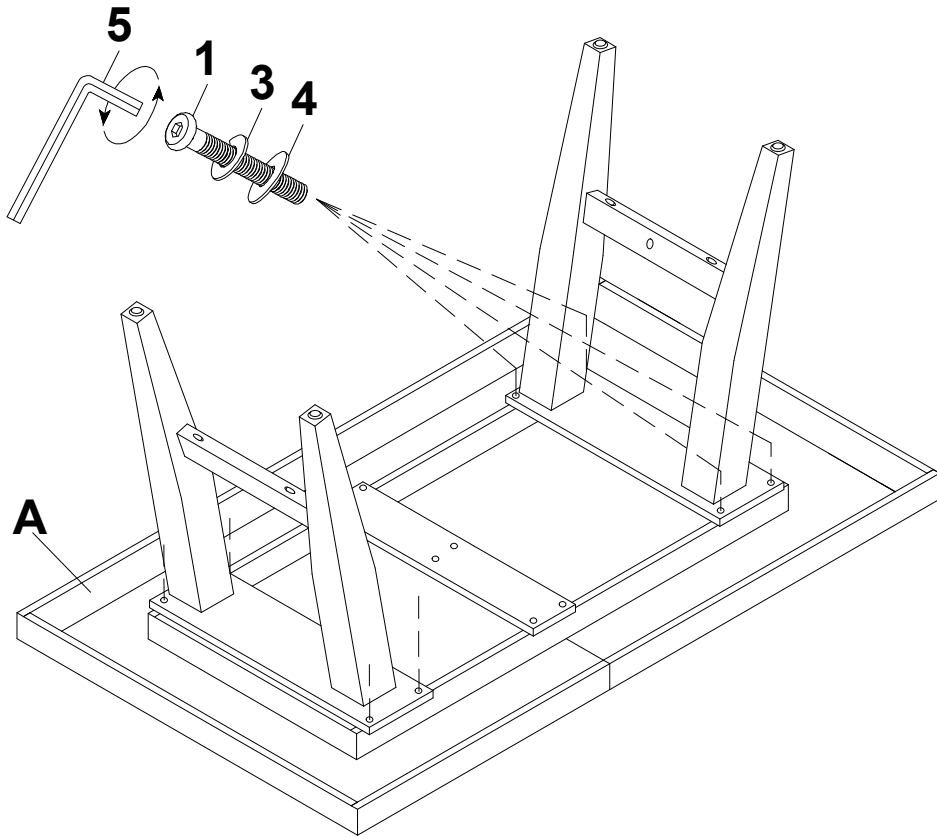

### STEP 5 / ÉTAPE 5

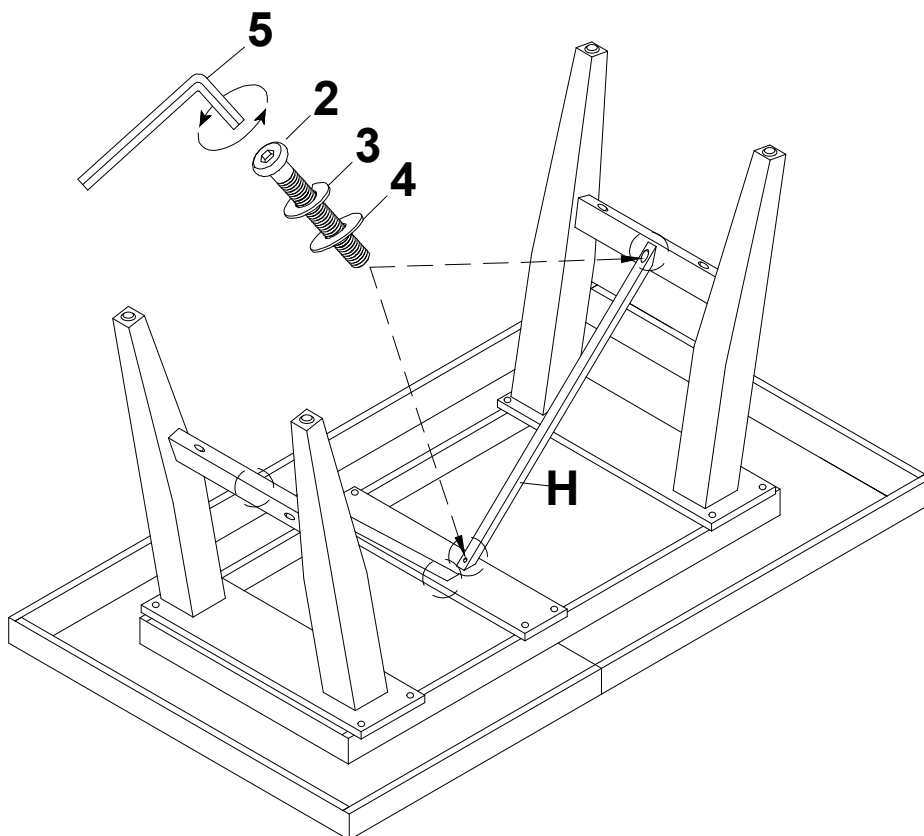

# ASSEMBLY INSTRUCTIONS / NOTICE D'ASSEMBLAGE

## ITEM : JYP-2326T DINING TABLE

### STEP 6 / ÉTAPE 6

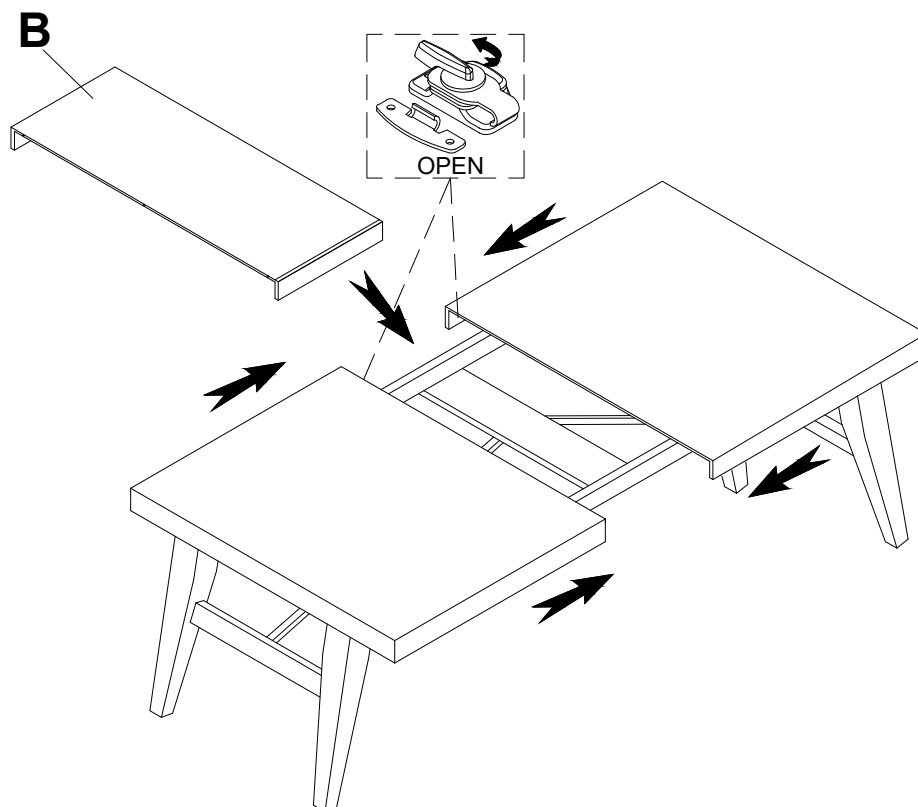

### COMPLETE

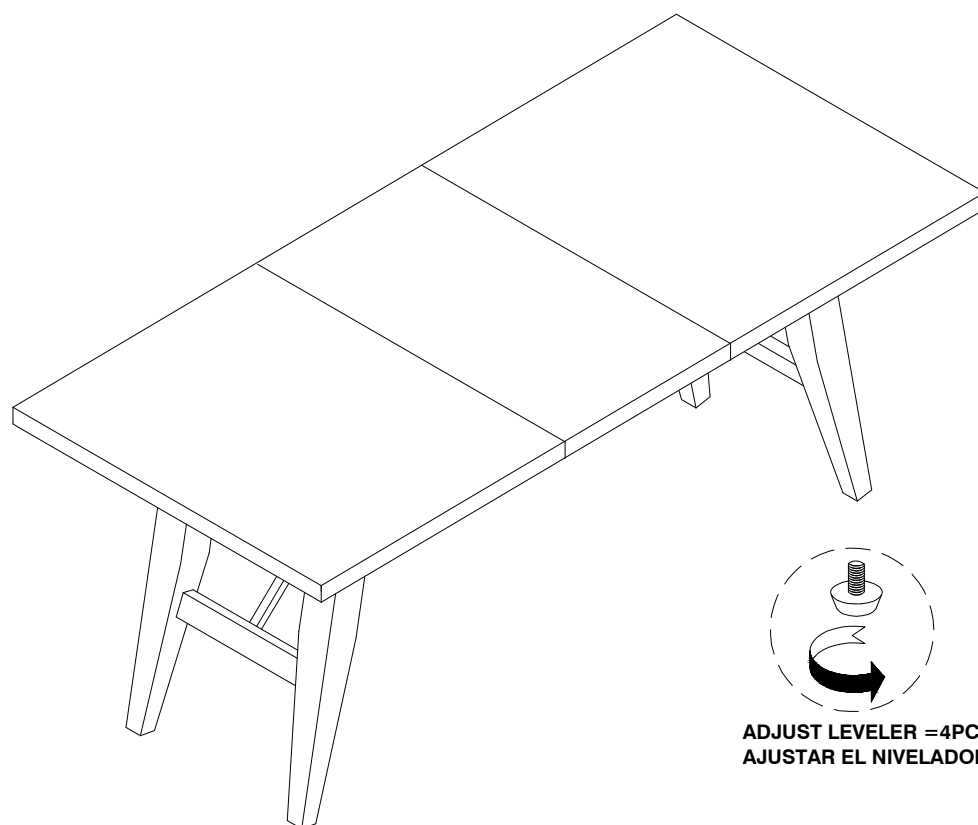







# ASSEMBLY INSTRUCTIONS / NOTICE D'ASSEMBLAGE

## ITEM: JYP-2326C DINING CHAIR

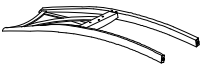



Important note/ Note importante:

1. Place all wooden parts on a clean and smooth surface such as a rug or carpet to avoid scratching the parts. / Placer les pièces sur une surface propre et lisse tel qu'une couverture ou un tapis pour éviter d'endommager les pièces.
2. Kindly follow the assembly instructions step by step./ Veuillez suivre la notice d'assemblage, pas à pas.
3. Do not tighten all screws and bolts until the table is fully assembled./ Ne serrer les vis et boulons à fond que lorsque le produit est entièrement assemblé.
4. Unscrew the protective plastique supports from the metal insert of the legs before assembly./ Dévisser les caches plastiques des embouts métalliques des pieds de la table avant l'assemblage.

### PARTS IDENTIFICATION / IDENTIFICATION DES PIÈCES

<b>A</b> Chair Back Dossier	<b>B</b> Seat Frame Coussin assise	<b>C</b> Front Leg(L) Pied Avant Gauche	<b>D</b> Front Leg(R) Pied Avant Droite	<b>E</b> Left Stretcher(L) Traverse côté Gauche	<b>F</b> Right Stretcher(R) Traverse côté Droite
					
1pc	1pc	1pc	1pc	1pc	1pc

### HARDWARE IDENTIFICATION / IDENTIFICATION DES PIÈCES MONTAGE

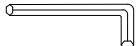
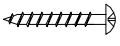
<b>1</b> Bolt Boulon Ø1/4"x60mm	<b>2</b> Bolt Boulon Ø1/4"x38mm	<b>3</b> Long Bolt Boulon long Ø1/4"x80mm	<b>4</b> Spring Washer Rondelle D'arret Ø1/4"x11mm	<b>5</b> Flat Washer Rondelle Plate Ø1/4"x19mm	<b>6</b> Allen Key Clé Allen M4	<b>7</b> Wood Screw Vis #8x45mm
						
4pcs	2pcs	4pcs	10 pcs	10 pcs	1pc	4pcs

#### STEP 1 / ÉTAPE 1

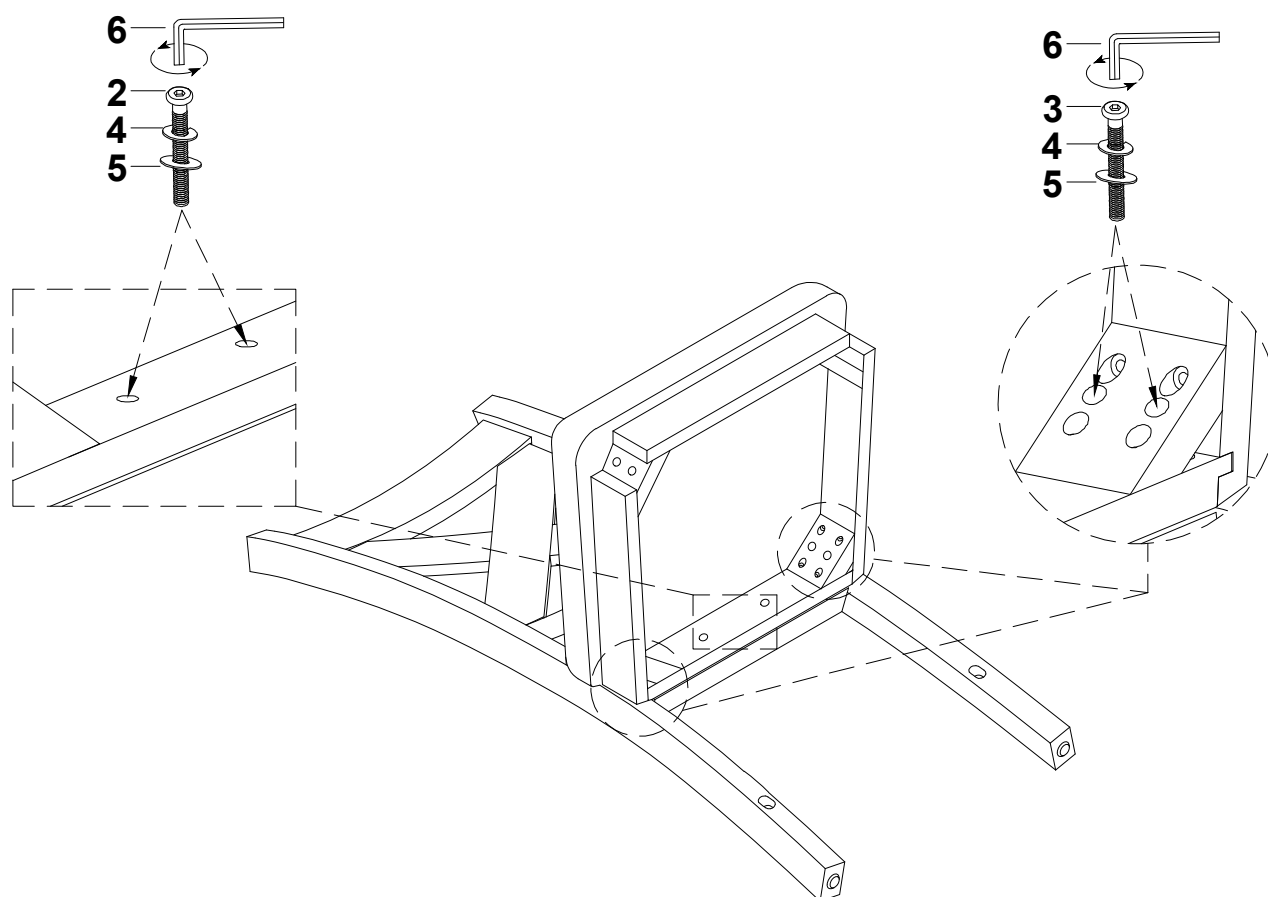

# ASSEMBLY INSTRUCTIONS / NOTICE D'ASSEMBLAGE

## ITEM: JYP-2326C DINING CHAIR

### STEP 2 / ÉTAPE 2

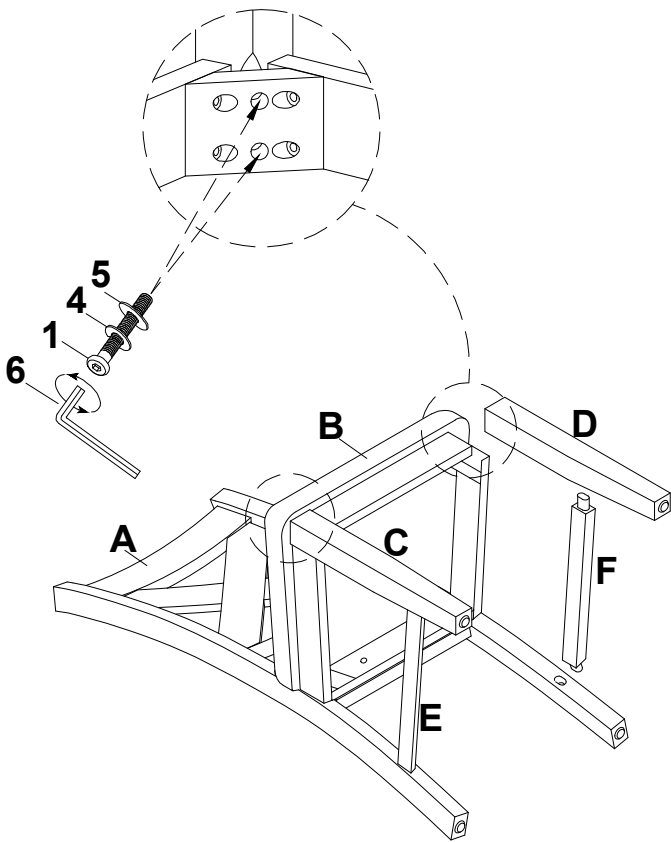

### STEP 3 / ÉTAPE 3

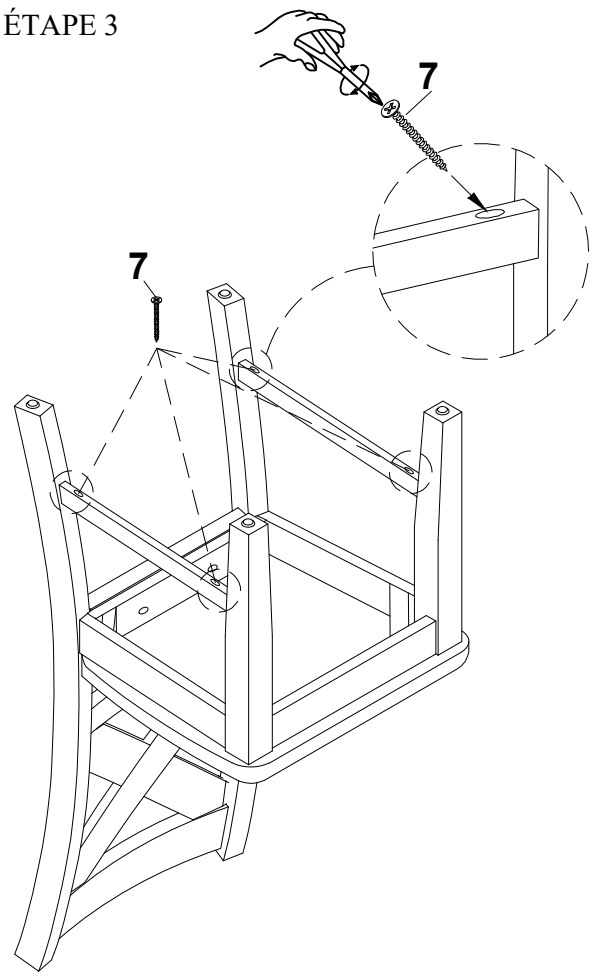

### COMPLETE

