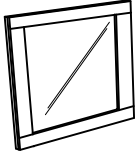

ASSEMBLY INSTRUCTIONS

MODEL : 40820 DRESSER & MIRROR

(BOX 1)

BOX OF MIRROR

NO	ITEM	QTY
	MIRROR	
A		1 PC

(BOX 2)

BOX OF DRESSER

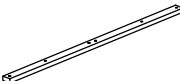
NO	ITEM	QTY
	DRESSER	
B		1 PC
	MIRROR SUPPORT	
C		2 PCS

(BOX 1)

BOX OF MIRROR

NO	ITEM	QTY
	FLAT HEAD CHIPBOARD SCREW m4 x 32mm RBW	
1		10 PCS

STEP 1 : Cut of the Raffia String from the back of DRESSER (B).

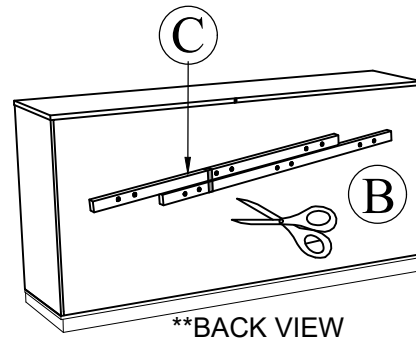

STEP 2 : Turn the MIRROR SUPPORT RAIL (C) upward at the back of DRESSER (B), then Tighten with CSK SCREW (1). Place the MIRROR FRAME (A) on the top of DRESSER (B). Tighten with Flat Head Chipboard Screw (1).

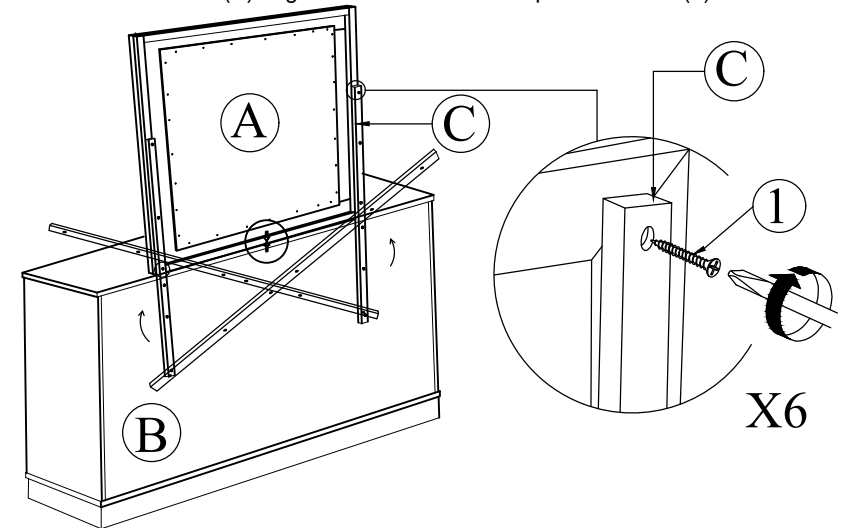

STEP 3 : Tighten the Flat Head Chipboard Screw (1) as shown.

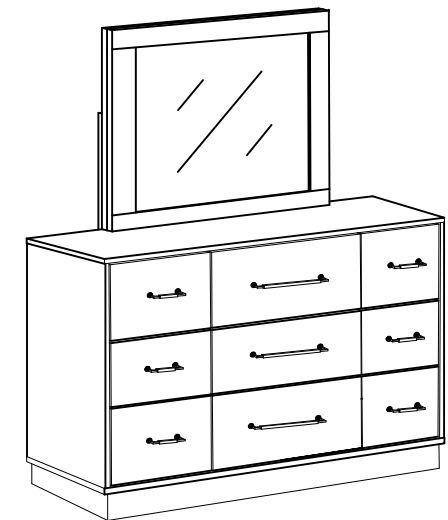
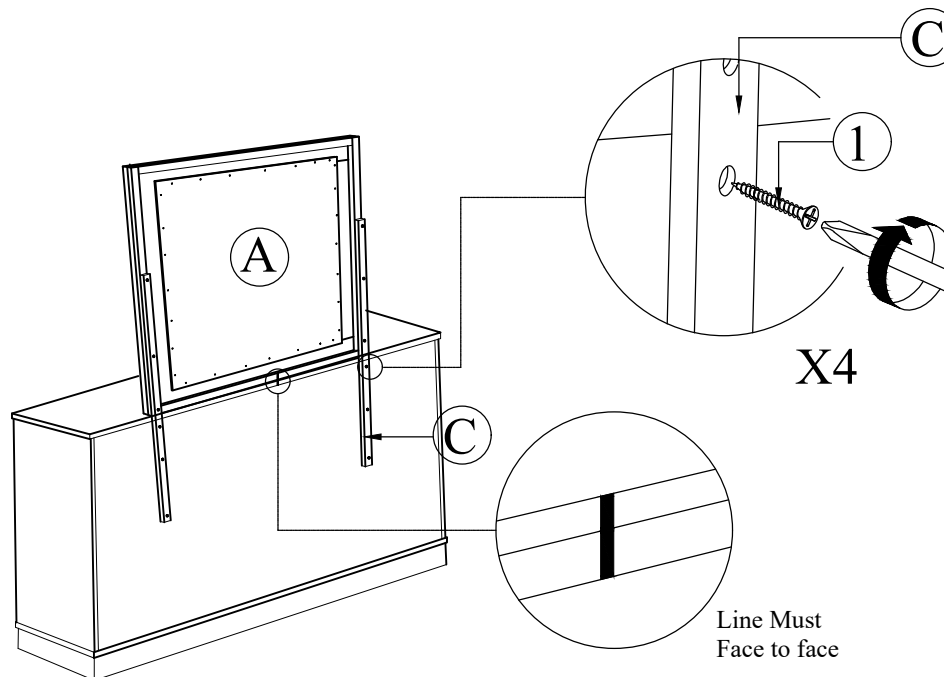

COMPLETE ASSEMBLY

NOTE : MUST TIGHTEN SCREWS PERIODCALLY WITH USE SCREW WILL BECOME LOOSE CHECK TIGHTNESS OF ALL SCREW EVERY 6-8 WEEKS.

INSTRUCTIONS D'ASSEMBLAGE

MODÈLE : 40820
COMMODE & MIROIR

(Cart. 1)
CARTON MIROIR

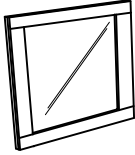
N°	PIÈCE MIROIR	Qté
A		1 PCE

(Cart. 2)
CARTON COMMODE

N°	PIÈCE COMMODE	Qté
B		1 PCE

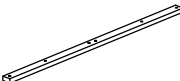
N°	PIÈCE RENFORT DU MIROIR	Qté
C		2 PCES

(Cart. 2)
QUINCAILLERIE

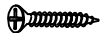
N°	PIÈCE VIS m4 x 32mm	Qté
1		10 PCES

ÉTAPE 1 : Coupe du fil de raphia du dos de la COMMODE (B).

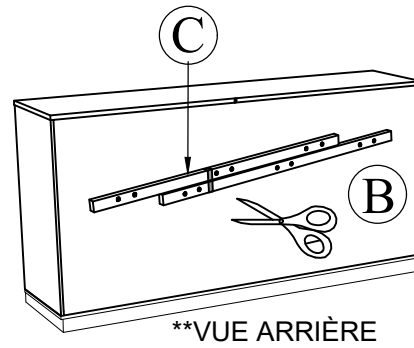

ÉTAPE 2 : Tournez le RAIL DE SUPPORT DE MIROIR (C) vers le haut à l'arrière de la COMMODE (B), puis Serrez avec la VIS CSK (1). Placez le CADRE DE MIROIR (A) sur le dessus de la COMMODE (B). Serrez avec une vis pour panneaux d'aggloméré à tête plate (1).

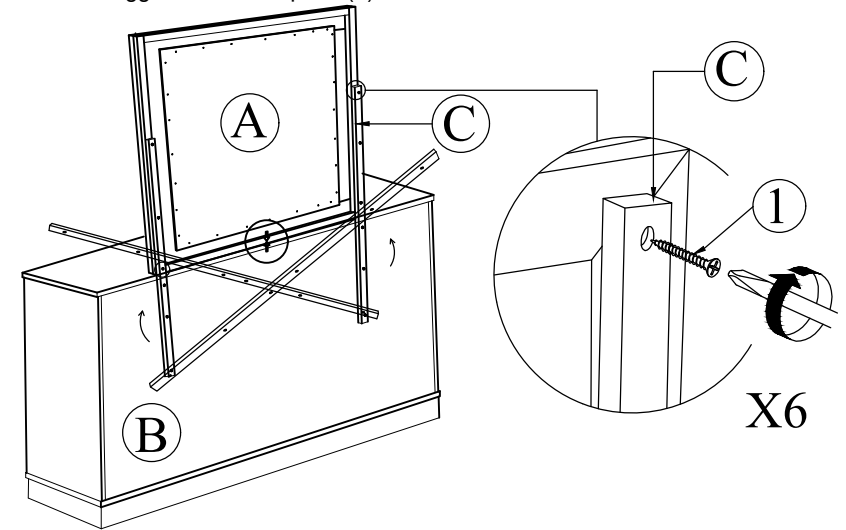

ÉTAPE 3 : Serrez la vis pour panneau d'aggloméré à tête plate (1) comme indiqué.

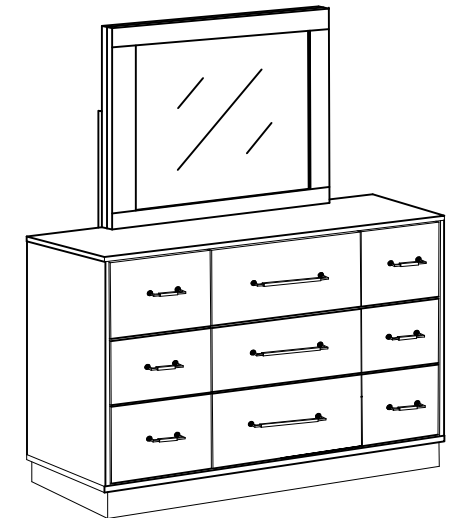
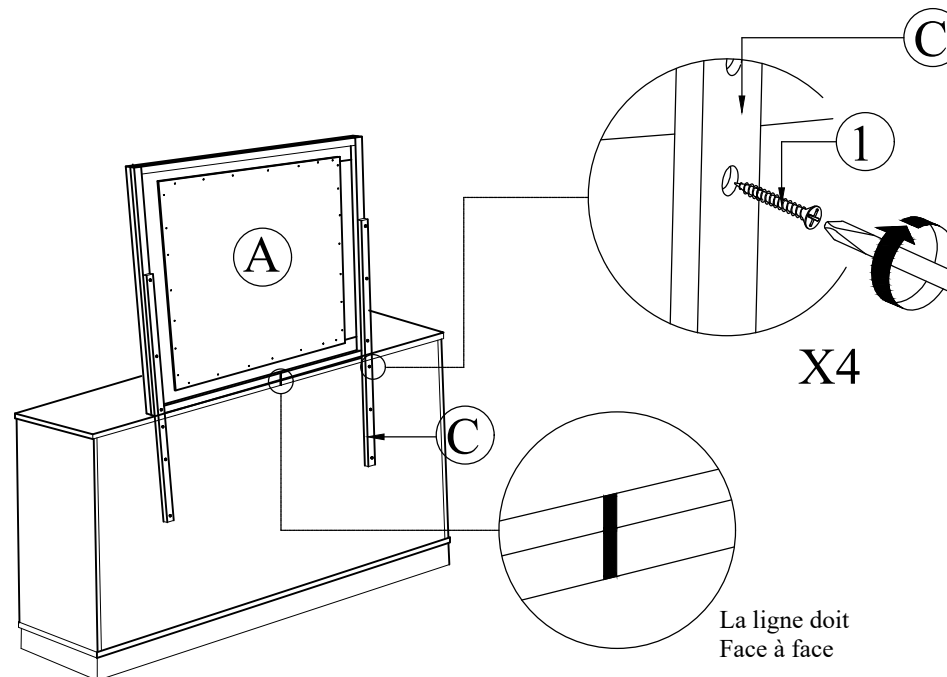

ASSEMBLAGE COMPLET

NOTE : MUST TIGHTEN SCREWS PERIODCALLY WITH USE SCREW WILL BECOME LOOSE CHECK TIGHTNESS OF ALL SCREW EVERY 6-8 WEEKS.