

# ASSEMBLY INSTRUCTIONS / NOTICE D'ASSEMBLAGE

## ITEM : JYP-2324T DINING TABLE

### Important note/ Note importante:

1. Place all wooden parts on a clean and smooth surface such as a rug or carpet to avoid scratching the parts. / Placer les pièces sur une surface propre et lisse tel qu'une couverture ou un tapis pour éviter d'endommager les pièces.
2. Kindly follow the assembly instructions step by step./ Veuillez suivre la notice d'assemblage, pas à pas.
3. Do not tighten all screws and bolts until the table is fully assembled./ Ne serrer les vis et boulons à fond que lorsque le produit est entièrement assemblé.
4. Unscrew the protective plastic supports from the metal insert of the table legs before assembly./ Dévisser les caches plastiques des embouts métalliques des pieds de la table avant l'assemblage.

### PARTS IDENTIFICATION / IDENTIFICATION DES PIÈCES

**A** Table Top  
Dessus de Table

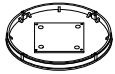

1pc

**B** Middle Connect Board  
Panneau De Connection

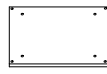

1pc

**C** Bend Panel  
Plier Le Panneau



4pcs

**D** Pedestal  
Piédestal



1pc

**E** Bottem connect board  
Panneau De Connection



1pc

**F** Foot Base  
Base De Pied



4pcs

### HARDWARE IDENTIFICATION / IDENTIFICATION DES PIÈCES MONTAGE

**1** Bolt  
Boulon

Ø5/16"x38mm



20pcs

**2** Spring Washer  
Rondelle D'arret

Ø5/16"x11mm



20pcs

**3** Flat Washer  
Rondelle Plate

Ø5/16"x19mm



20pcs

**4** Allen Key  
Clé Allen

M4



1pc

### STEP 1 / ÉTAPE 1

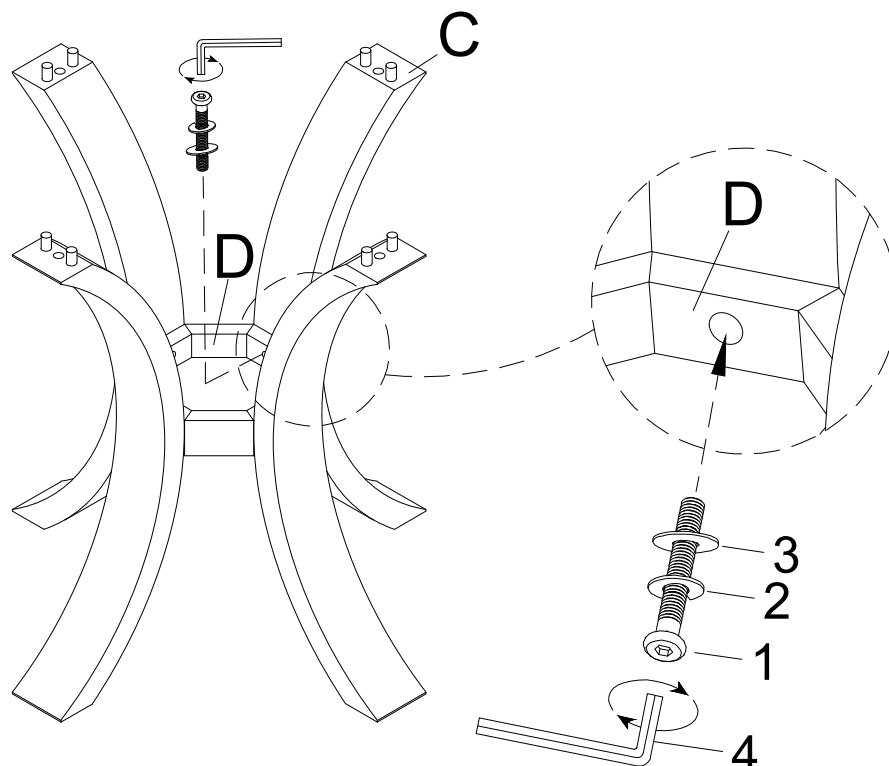

ASSEMBLY INSTRUCTIONS / NOTICE D'ASSEMBLAGE  
ITEM : JYP-2324T DINING TABLE

STEP 2 / ÉTAPE 2

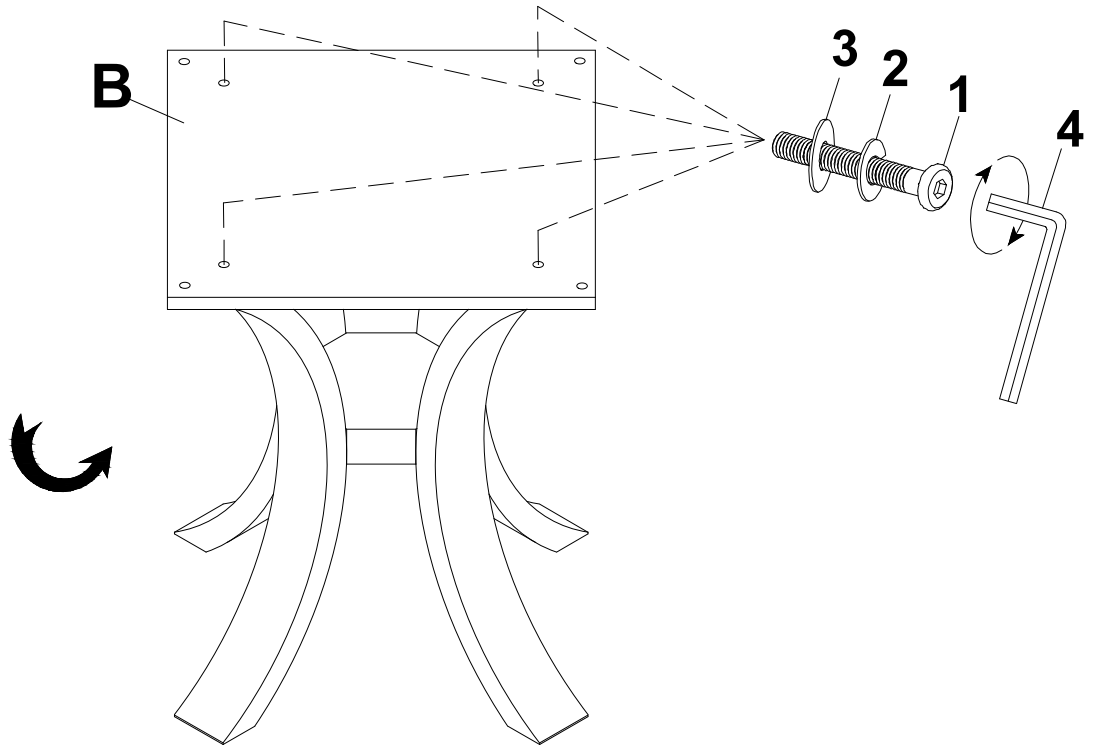

STEP 3 / ÉTAPE 3

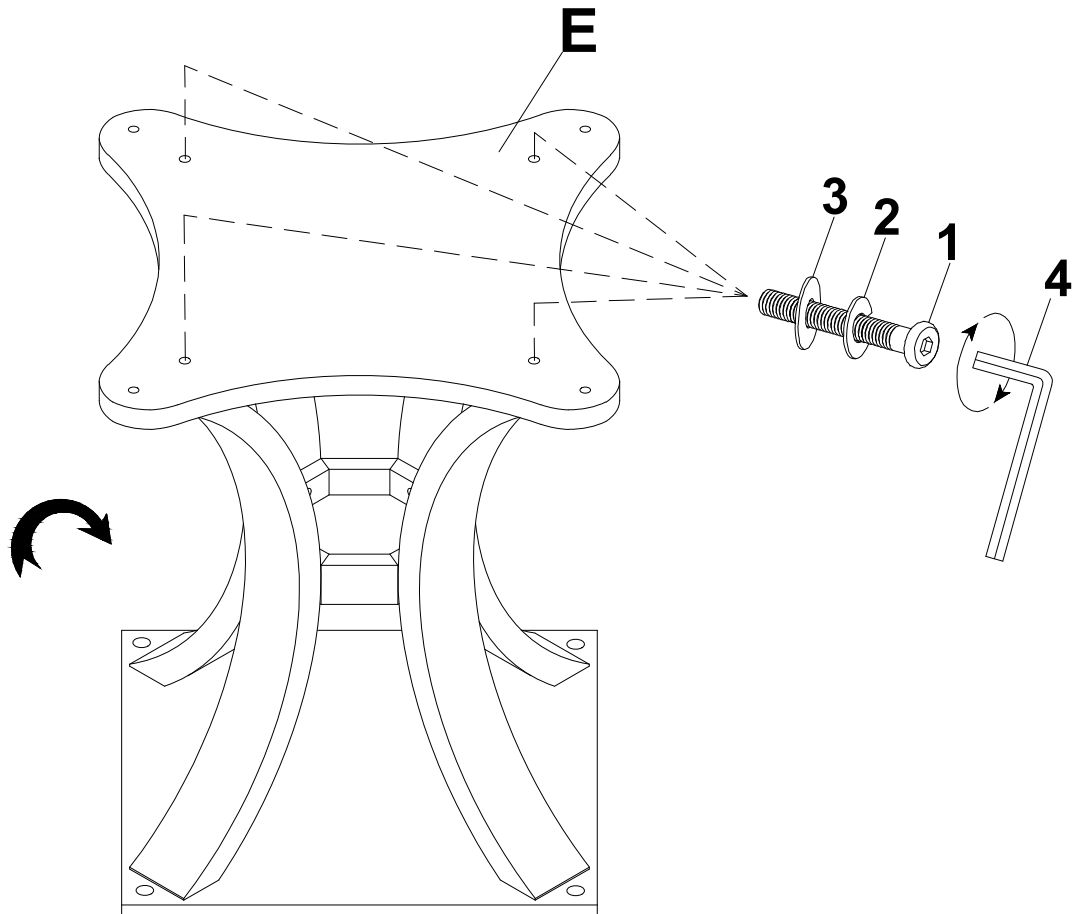

ASSEMBLY INSTRUCTIONS / NOTICE D'ASSEMBLAGE  
ITEM : JYP-2324T DINING TABLE

STEP 4 / ÉTAPE 4

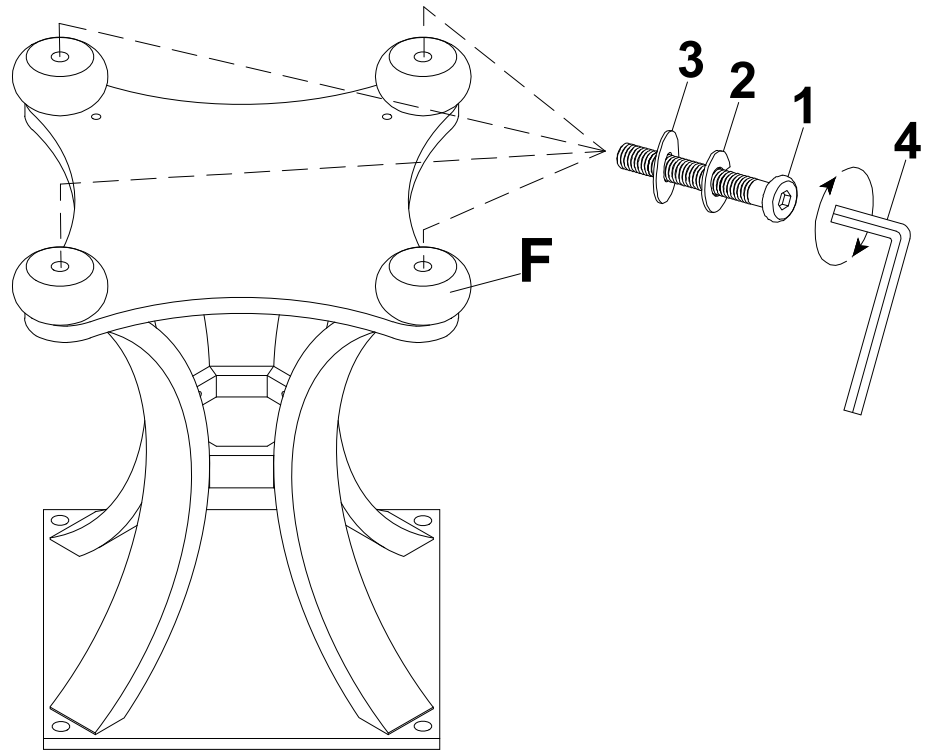

STEP 5 / ÉTAPE 5

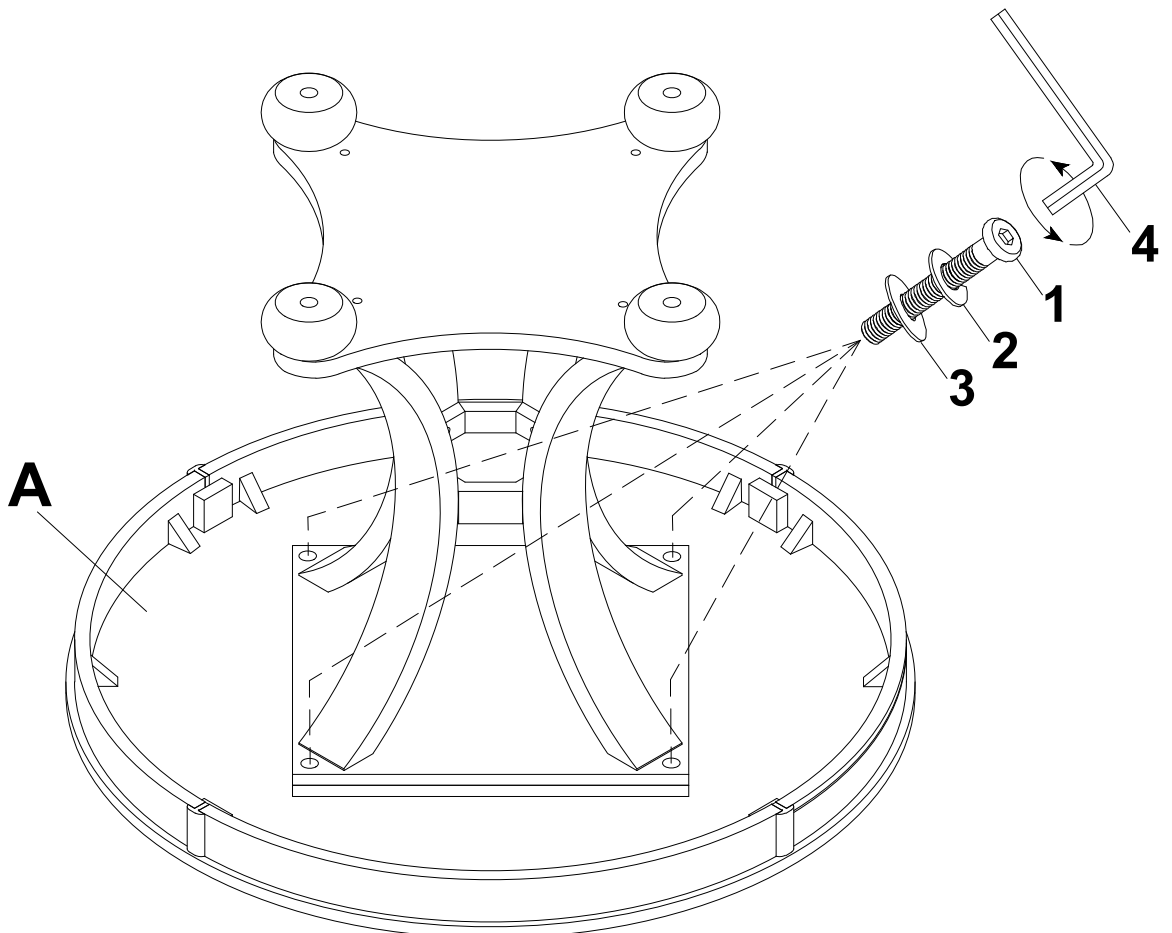

ASSEMBLY INSTRUCTIONS / NOTICE D'ASSEMBLAGE  
ITEM : JYP-2324T DINING TABLE

COMPLETE

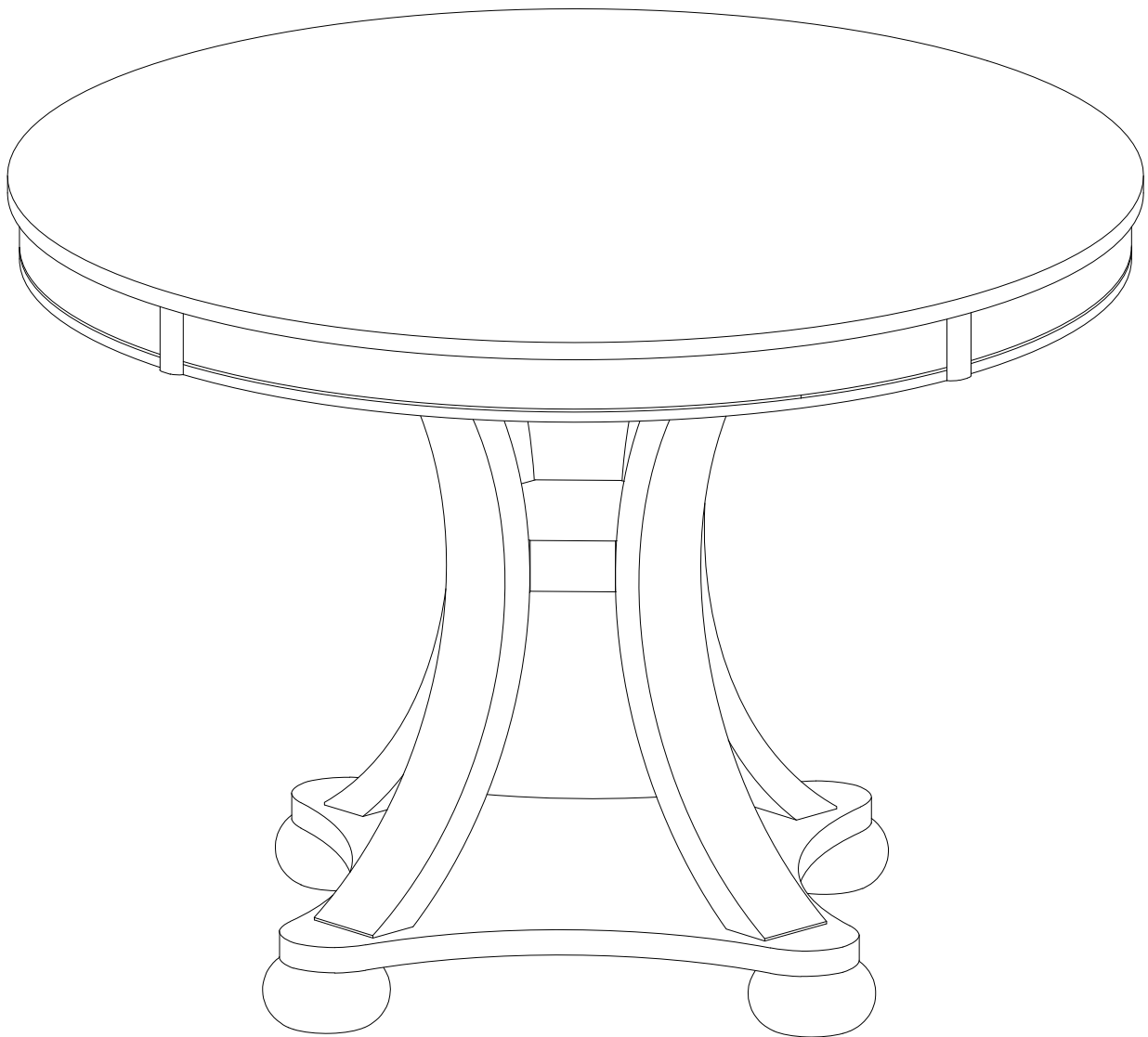

# ASSEMBLY INSTRUCTIONS / NOTICE D'ASSEMBLAGE

## ITEM: JYP-2324C DINING CHAIR

Important note/ Note importante:

1. Place all wooden parts on a clean and smooth surface such as a rug or carpet to avoid scratching the parts. / Placer les pièces sur une surface propre et lisse tel qu'une couverture ou un tapis pour éviter d'endommager les pièces.
2. Kindly follow the assembly instructions step by step./ Veuillez suivre la notice d'assemblage, pas à pas.
3. Do not tighten all screws and bolts until the table is fully assembled./ Ne serrer les vis et boulons à fond que lorsque le produit est entièrement assemblé.
4. Unscrew the protective plastique supports from the metal insert of the legs before assembly./ Dévisser les caches plastiques des embouts métalliques des pieds de la table avant l'assemblage.

### PARTS IDENTIFICATION / IDENTIFICATION DES PIÈCES

**A** Chair Back  
Dossier

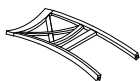

1pc

**B** Wooden Seat  
Coussin assise

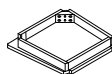

1pc

**C** Front Leg  
Pied Avant



2pcs

### HARDWARE IDENTIFICATION / IDENTIFICATION DES PIÈCES MONTAGE

**1** Bolt  
Boulon  
Ø1/4"x60mm



4pcs

**2** Bolt  
Boulon  
Ø1/4"x38mm



2pcs

**3** Long Bolt  
Boulon long  
Ø1/4"x80mm



4pcs

**4** Spring Washer  
Rondelle D'arret  
Ø1/4"x11mm



10 pcs

**5** Flat Washer  
Rondelle Plate  
Ø1/4"x19mm



10 pcs

**6** Allen Key  
Clé Allen  
M4



1pc

### STEP 1 / ÉTAPE 1

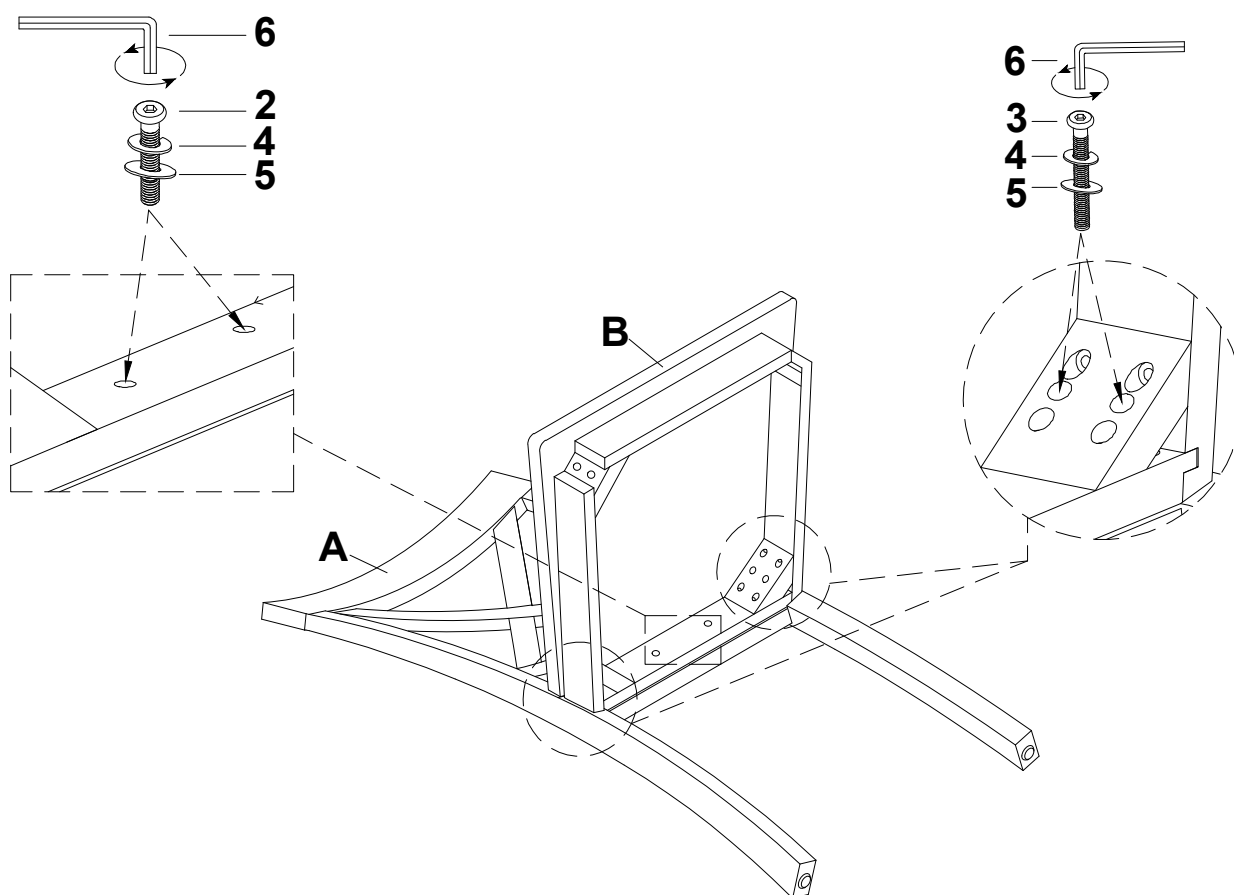

ASSEMBLY INSTRUCTIONS / NOTICE D'ASSEMBLAGE  
ITEM: JYP-2324C DINING CHAIR

STEP 2 / ÉTAPE 2

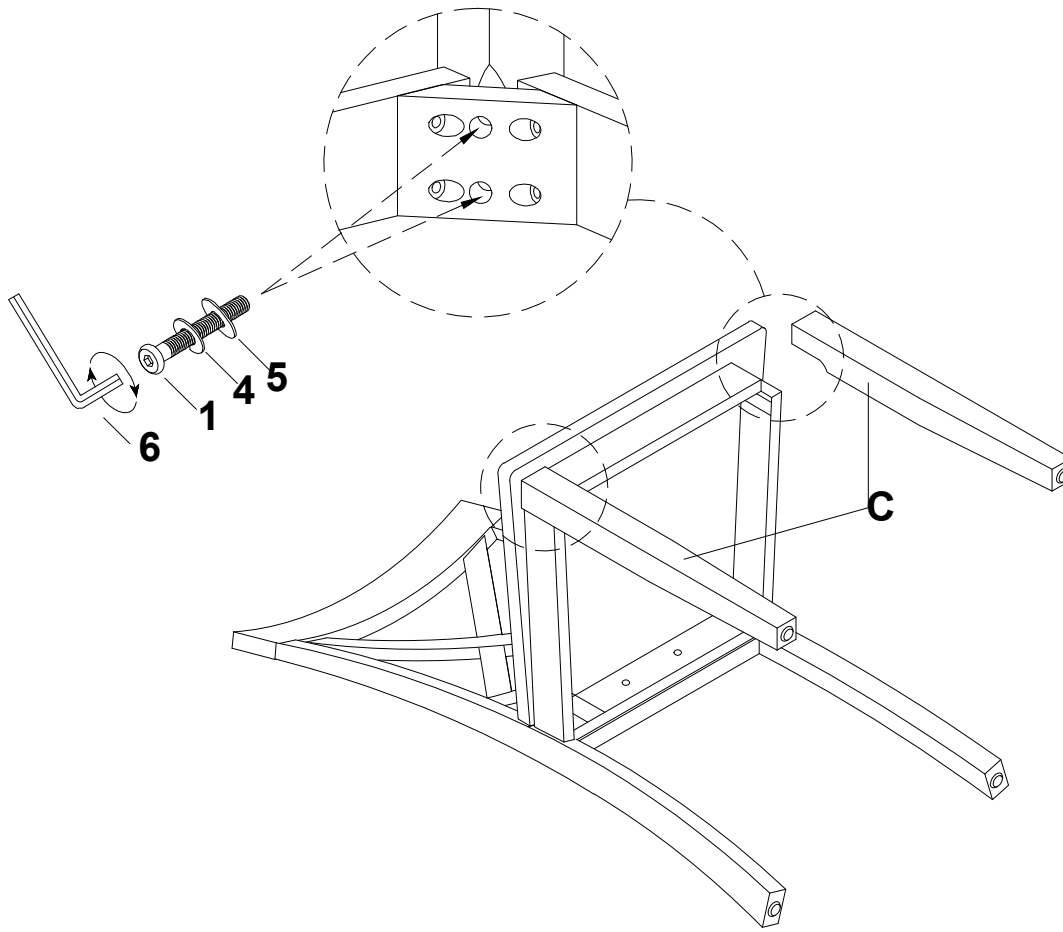

COMPLETE

