



BRASSEX INC.
THE FURNITURE PEOPLE
SINCE 1985

ASSEMBLY INSTRUCTIONS INSTRUCTIONS D'ASSEMBLAGE

11624/11625/11626

HARDWARE LIST IDENTIFICATION DU LIT

NO.	SKETCH	DESCRIPTION	QTY
A		Bolt(5/16 "x3-1/2") Boulon	4 PCS 4 PCES
B		Bolt(5/16 "x2-1/4") Boulon	5 PCS 5 PCES
C		Lock washer(5/16") Rondelle plate	9 PCS 9 PCES
D		Flat washer(5/16") Rondelle plate	9 PCS 9 PCES
E		Allen wrench(4mm) Clé hexagonale	1 PCS 1 PCES
F		Wood Dowel (Ø10x30mm) Cheville de bois	2 PC 2 PCE
G		Flat Head Screw (Ø10x30mm) Vis à tête plate	6 PC 6 PCE

PARTS LIST

NO.	SKETCH	DESCRIPTION	QTY
1		Backrest Dossier	1 PC 1 PCE
2		Seat Siège	1 PC 1 PCE
3		Front leg Pied avant	2 PC 2 PCE
4		Front stretcher Entrejambe avant	1 PC 1 PCE
5		Side stretcher Entrejambe côté	2 PC 2 PCE

Step 1
Étape 1

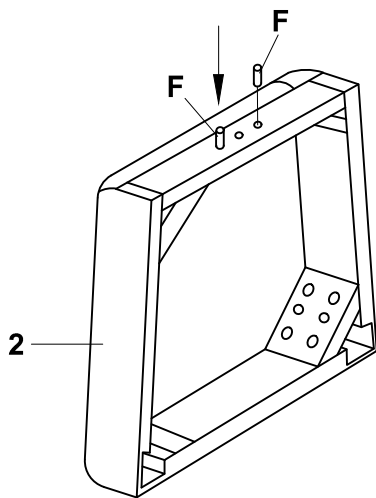

Step 2
Étape 2

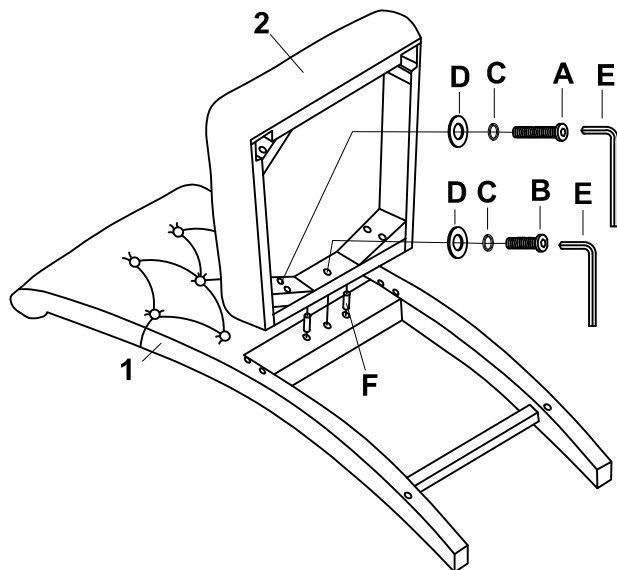



BRASSEX INC.
THE FURNITURE PEOPLE
SINCE 1985

ASSEMBLY INSTRUCTIONS INSTRUCTIONS D'ASSEMBLAGE

11624/11625/11626

Step 3 Étape 3

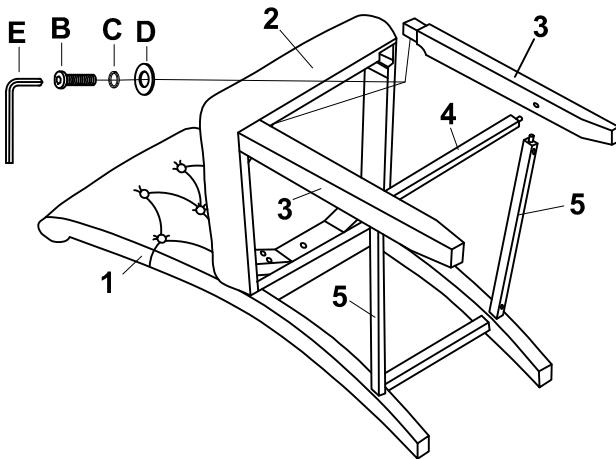

Note: Do not fully tighten the bolts at this step.
Note : Ne pas serrer complètement les boulons à cette étape.

Step 4 Étape 4

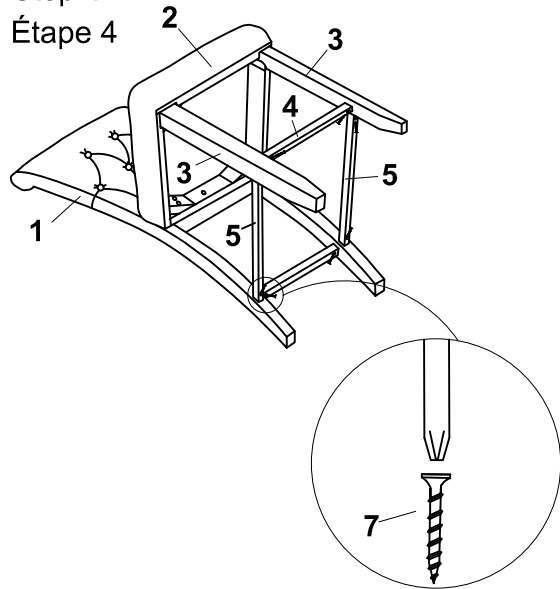

Note: Do not fully tighten the bolts at this step.
Note : Ne pas serrer complètement les boulons à cette étape.

Step 5 Étape 5

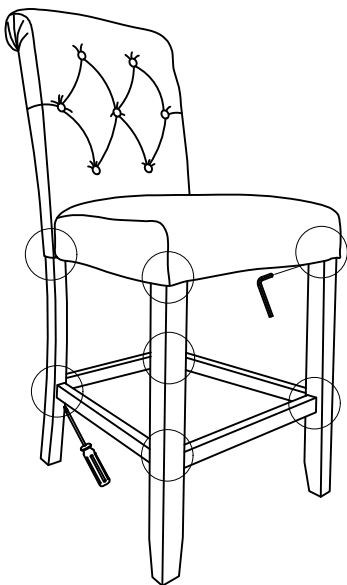

Note: Note: Once the assembly is completed, proceed to tighten all bolts sequentially.
Remarque : une fois l'assemblage terminé, serrez tous les boulons dans l'ordre.

Step 6 Étape 6

